

8 7 6 5 4 3 2 1

THE INFORMATION CONTAINED IN THIS DRAWING IS THE SOLE PROPERTY PREMIER MOUNTS (OR PMP). ANY REPRODUCTION IN PART, OR WHOLE, WITHOUT THE WRITTEN PERMISSION OF PREMIER MOUNTS (OR PMP) IS PROHIBITED

REVISIONS			
REV.	DESCRIPTION	DATE	APPROVED

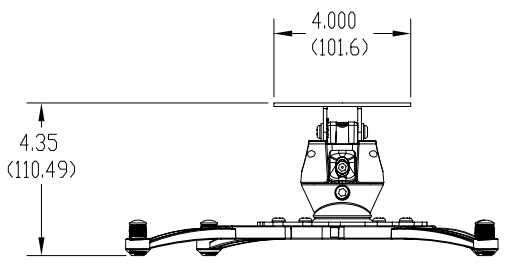
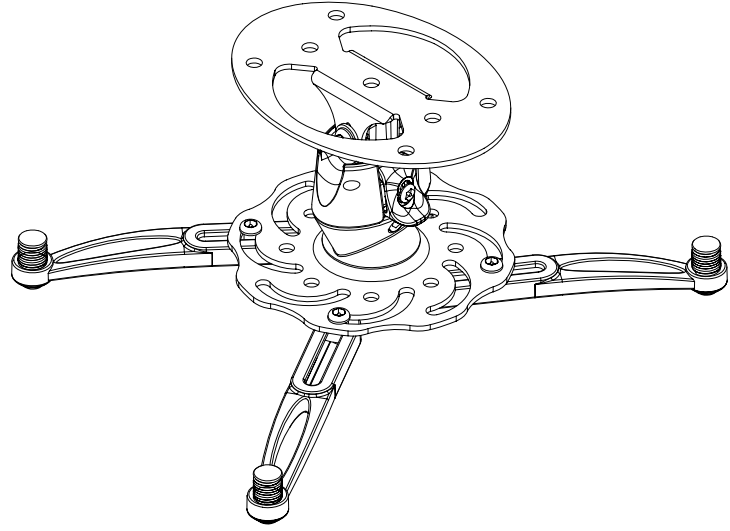
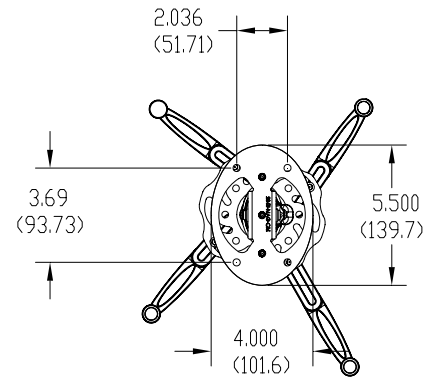

Architectural Specifications
 The projector mount will be a Premier Mounts Polaris Mount, or equivalent, and can be used to mount projectors a variety of ceiling structures. It will mount to wood joists or concrete. It will be made of cold-rolled steel. It will feature MagnaGuide Technology which assists the installer for quicker installation times. It will be UL listed and approved. It will incorporate security screws at all mounting and adjustment points. Assembly and installation will be performed according to the instructions provided by the manufacturer.

Surface Types - Ceiling Structures
 Weight Capacity - 10LBS.
 Dimensions - 4.00" (W) x 4.35" (H)
 Attachment - Wood Screws or Concrete Anchors

