



PLANAR m57L

The Planar m57L is a commercial-grade direct-view LCD monitor designed for high definition control room applications. It combines leading-edge resolution, high reliability and long-life expectancy in a thin monitor, ideal for displaying mission-critical data. The m57L is the new standard in flat-panel performance and is compatible with many processors and AV components.



FEATURES

Very large format
57" diagonal

Superior resolution
High definition 1080p
(1920 x 1080)

High image quality
Direct-view LCD,
178° viewing angle

Long life
50,000 hrs to 1/2 brightness
Ambient light sensor can automatically
adjust backlight

Fits any control room
< 5" deep, low power,
Field serviceable

Integrated tiling capabilities
Integrated Big Picture™
Mullion compensation

Integrated scheduling
Built in power on/off
Source switching

PLANAR m57L

Display technology	Direct-view LCD*
Display resolution	1920 x 1080p
Aspect ratio (W:H)	16:9
Screen dimensions	
Diagonal	57" (143.74 cm)
Width by height	49.33" x 27.74" (125.28 cm x 70.47 cm)
Cabinet dimensions (WxHxD)	53.7" x 31.5" x 4.76" (136.36 cm x 80.08 cm x 12.11 cm)
Screen brightness	600 nits (175 ftL)
Response time	8ms total typical
Contrast ratio (full field)	1200:1
Full viewing angle	178°
Colors	16.7 million
Color gamut	72% NTSC, 100% EBU
Weight*	105 lbs (48kg)
Backlight type	CCFL
Backlight life (1/2 brightness)	50,000 hours
Line voltage	100-120/200-240VAC 50/60Hz (auto switching)
Power consumption	~350 watts
Operating temperature	32-90°F (0-32°C)
Operating humidity	20-80% RH non-condensing
Safety regulations	Complies with EN60950, FCC Class A, CE, EN55022 (CISPR22)
Data input (base model)	Analog VGA (640 x 480) to full HD (1080p) DSUB 15 pin connector DVI-D (with loop through)
Video input (video model)	Composite video (NTSC, PAL, SECAM) RCAx1 Component video (NTSC, PAL, VGA-1080p) RCAx3 S-Video (NTSC, PAL) Mini DIN 4-pin connector SDI (NTSC, PAL, 720, 1080i) BNCx1 (with loop through)
Frame lock	50-65Hz
Display control	RS-232 (with loop out) and IR remote
Ambient noise	Fanless
Mullion width (edge to active area)	56.1mm horizontal, 48.4mm vertical
Mounting pattern	VESA MIS-F, 1000, 200, 8
Power management	DPMS (standby, suspend)
Optional accessories	VESA wall mount adapters, table stand
MIP	Supported
Big Picture™	Integrated
Wallnet™	Supported

*Optical specifications without protective glass.

**Weight and dimensions are approximate. Specifications and design are subject to change without notice. This product may be subject to export control regulations.

PLANAR m57L: PRODUCT DIMENSIONS



For more information
 To learn more about the
 Planar m57L by Planar Systems,
 call 503-748-1100 or visit
www.planarcontrolroom.com
 or www.planardigitalsignage.com.

front

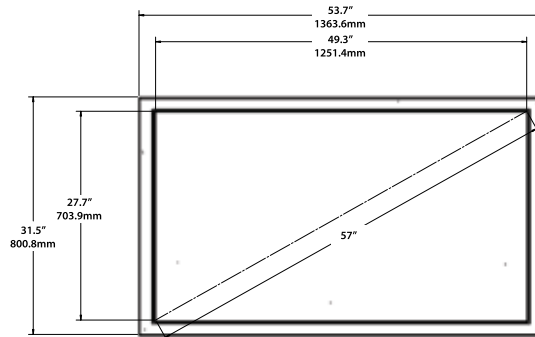

back

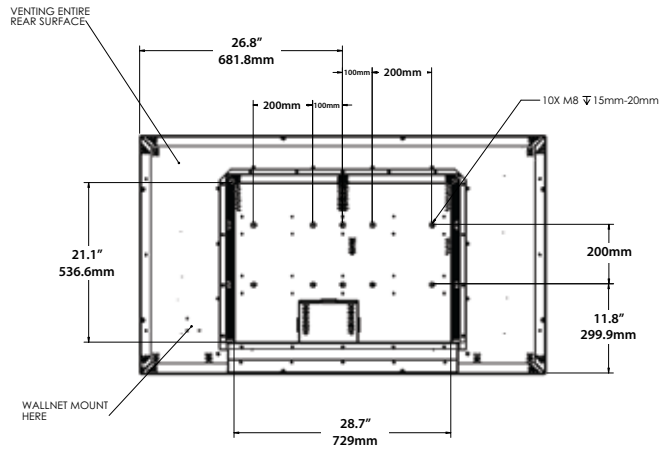

bottom

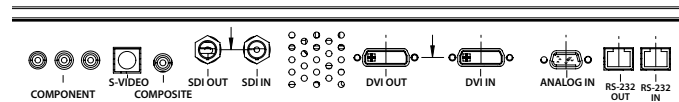

Planar Systems, Inc.
 1195 NW Compton Drive
 Beaverton, OR, 97006-1992, USA
 Toll Free +1-866-475-2627
www.planar.com

Planar is a trademark of Planar Systems, Inc. All other trade and service marks are the property of their holders.

Copyright © 2008 Planar Systems, Inc. All rights reserved. This document may not be copied in any form without written permission from Planar Systems, Inc. Information in this document is subject to change without notice.