

Note 1 : All dimensions are in mm

Note 2 : The base can handle 4 rows of cubes.

Note 3 : The base has to be fix on the ground as per ancrage_base_v30_fixation_plancher_informatique.pdf and ancrage_base_v30_principe_bom.pdf

Note 4 : The base can handle some options as covers, racks, ...

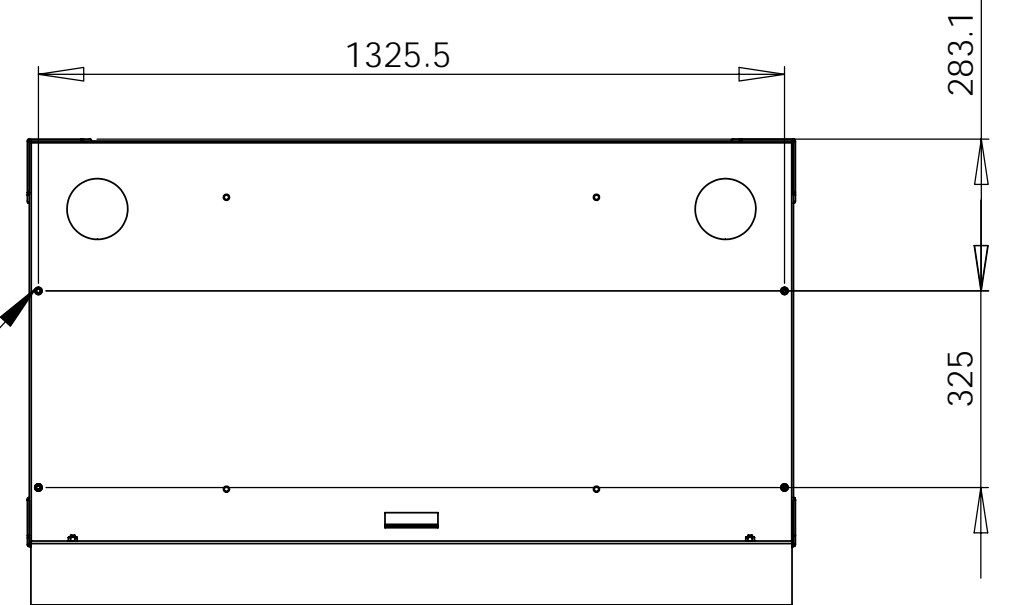
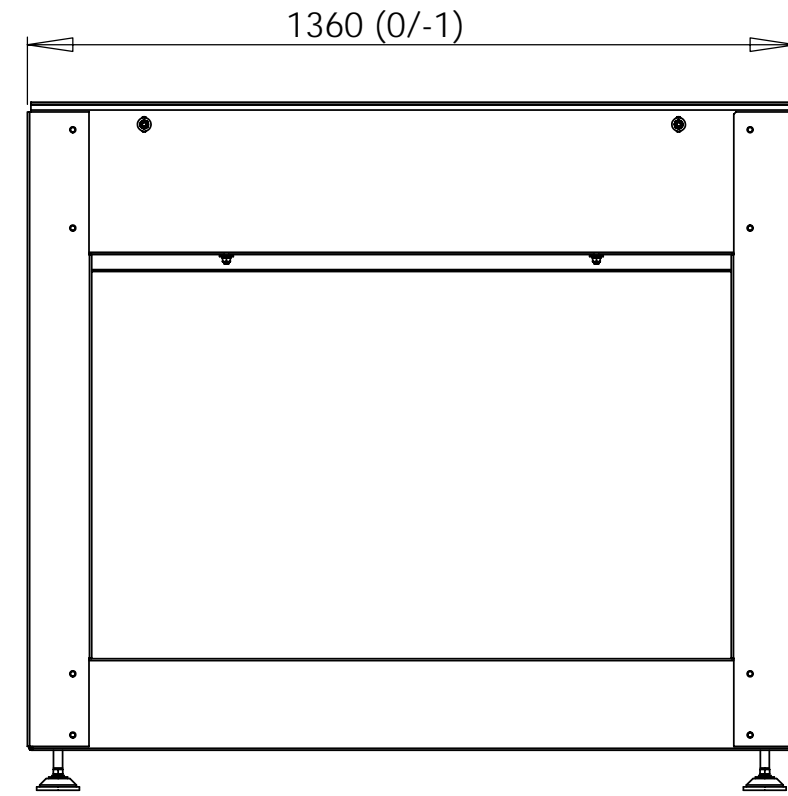
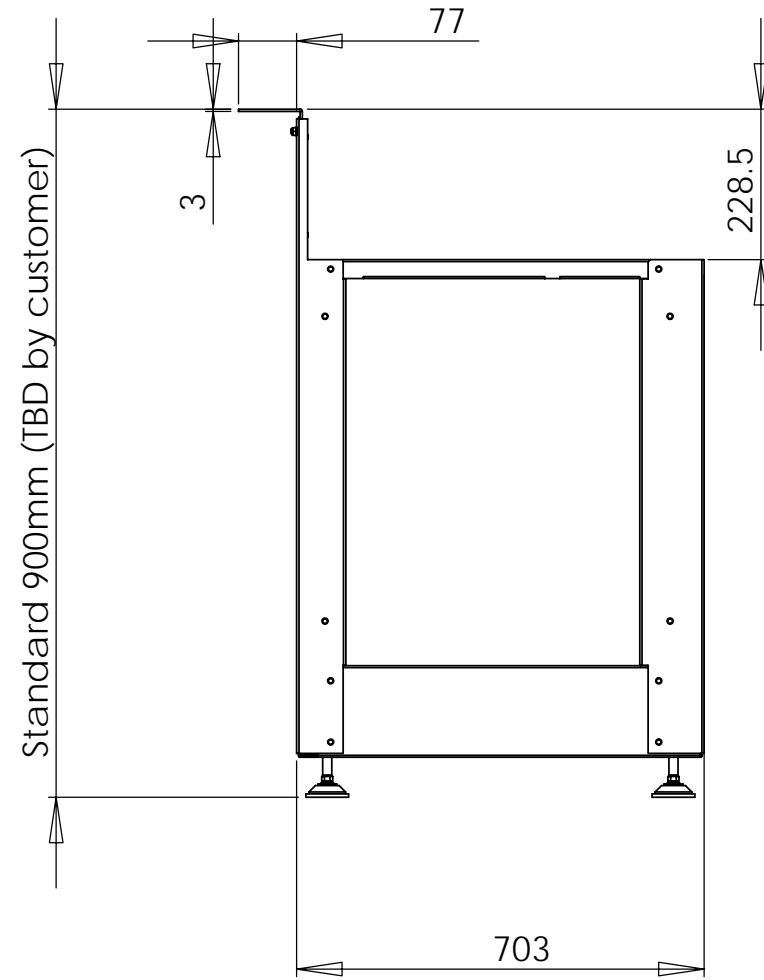
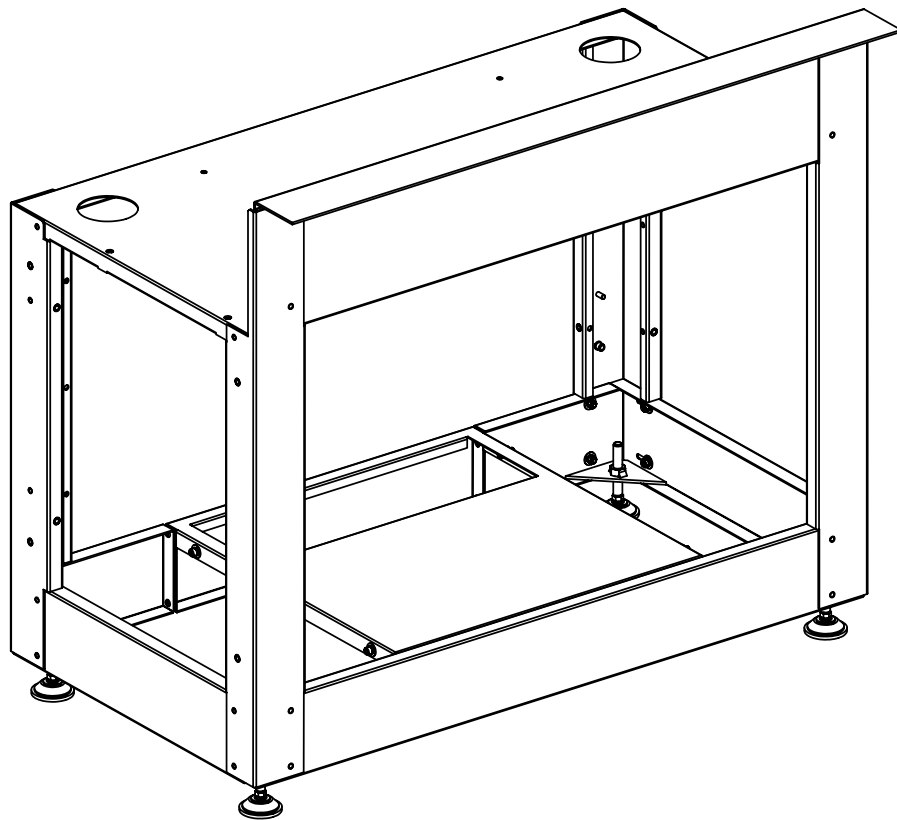

4 M6 screws
to fix the cube on the base

UNLESS OTHERWISE SPECIFIED: DIMENSIONS ARE IN MILLIMETERS SURFACE FINISH: TOLERANCES: LINEAR: ANGULAR: +/- .5mm		FINISH: RAL 9005		DEBUR AND BREAK SHARP EDGES		DO NOT SCALE DRAWING		REVISION 10	
DRAWN V DELMAS		SIGNATURE		DATE 06/03/2006		TITLE: c67_base_450270			
CHK'D									
APPV'D V DELMAS				DATE 06/03/2006					
MFG									
Q.A				MATERIAL: DC01 steel		DWG NO. c67_base_450280_v10		A3	
				WEIGHT: 40kg		SCALE:1/10		SHEET 1 OF 2	

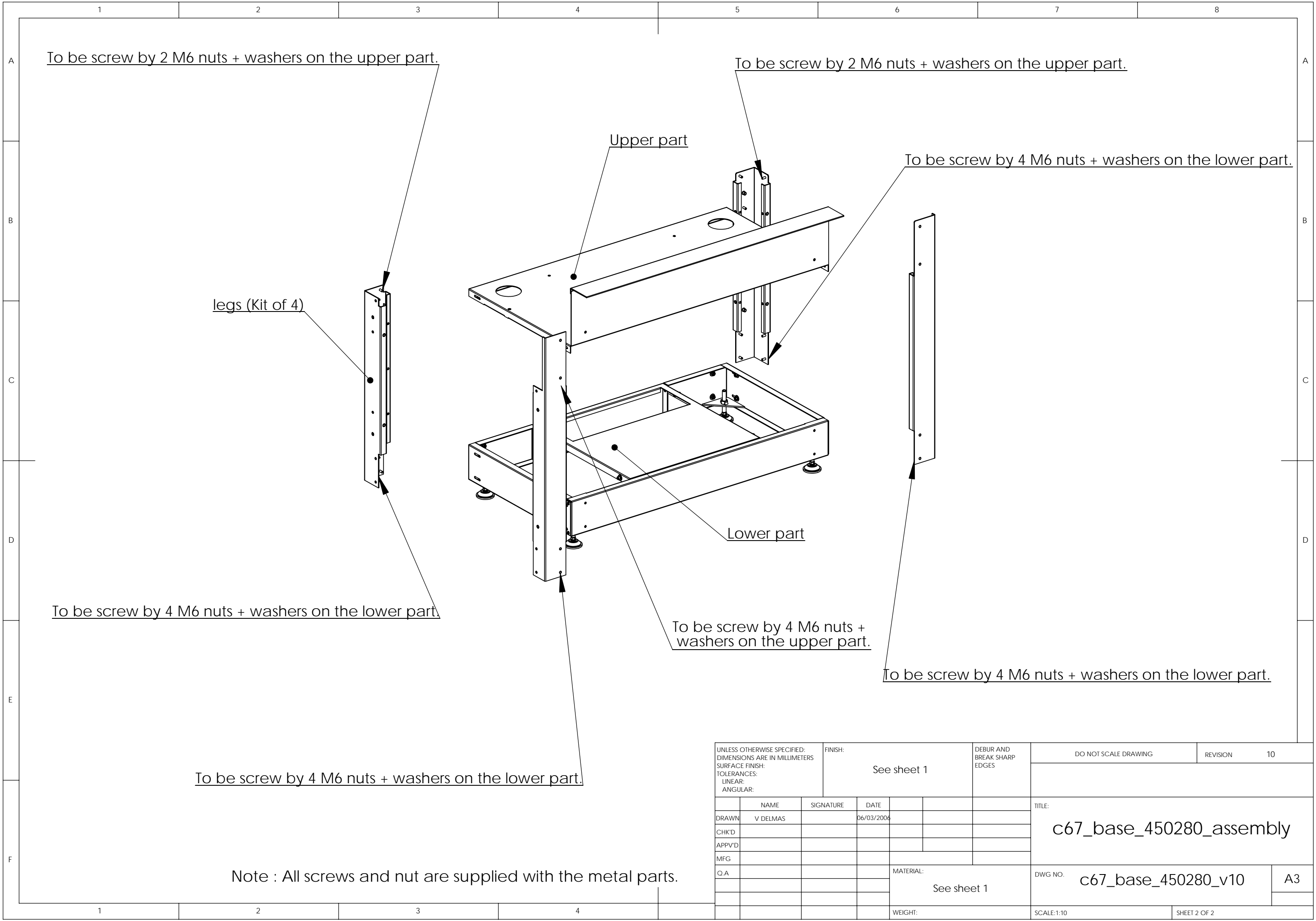

To be screw by 2 M6 nuts + washers on the upper part.

To be screw by 2 M6 nuts + washers on the upper part.

legs (Kit of 4)

Upper part

To be screw by 4 M6 nuts + washers on the lower part.

Lower part

To be screw by 4 M6 nuts + washers on the lower part.

To be screw by 4 M6 nuts + washers on the upper part.

To be screw by 4 M6 nuts + washers on the lower part.

To be screw by 4 M6 nuts + washers on the lower part.

Note : All screws and nut are supplied with the metal parts.

UNLESS OTHERWISE SPECIFIED: DIMENSIONS ARE IN MILLIMETERS		FINISH: See sheet 1		DEBUR AND BREAK SHARP EDGES		DO NOT SCALE DRAWING		REVISION 10	
SURFACE FINISH:									
TOLERANCES:									
LINEAR:									
ANGULAR:									
DRAWN		SIGNATURE		DATE		TITLE:			
V DELMAS				06/03/2006		c67_base_450280_assembly			
CHK'D									
APPV'D									
MFG									
Q.A						MATERIAL:		DWG NO. c67_base_450280_v10	
						See sheet 1		A3	
						WEIGHT:		SCALE:1:10	
								SHEET 2 OF 2	