

SCREEN ADJUSTMENTS IN X, Y, AND Z ARE ±2mm FROM NOMINAL.

		DRAWN BY EJS CHECKED BY DJLANS	PLANAR PLANAR SYSTEMS, INC. 1165 NW COMPTON DRIVE BEAVERTON, OR 97008 USA
MARGAY II OUTLINE			
TOLERANCES X= ±1 Y= ±5 ANGLES ±1° DIMENSIONS AND TOLERANCING PER ASME Y14.5M	XX= ±.25 YY= ±.25 ZZ= ±.25 THRU HOLE PROJECTION	PART NO. D MARGAY II	QUANTITY MARGAY II
1:5 DO NOT SCALE		2 OF 5	

THIS DRAWING IS THE PROPERTY OF PLANAR SYSTEMS, INC. AND IS NOT TO BE REPRODUCED OR TRANSMITTED IN ANY FORM OR BY ANY MEANS, ELECTRONIC OR MECHANICAL, INCLUDING PHOTOCOPYING, RECORDING, OR BY ANY INFORMATION STORAGE AND RETRIEVAL SYSTEM. PLANAR SYSTEMS, INC. IS NOT RESPONSIBLE FOR ANY DAMAGE TO PROPERTY OR PERSONS ARISING FROM THE USE OF THIS DRAWING.

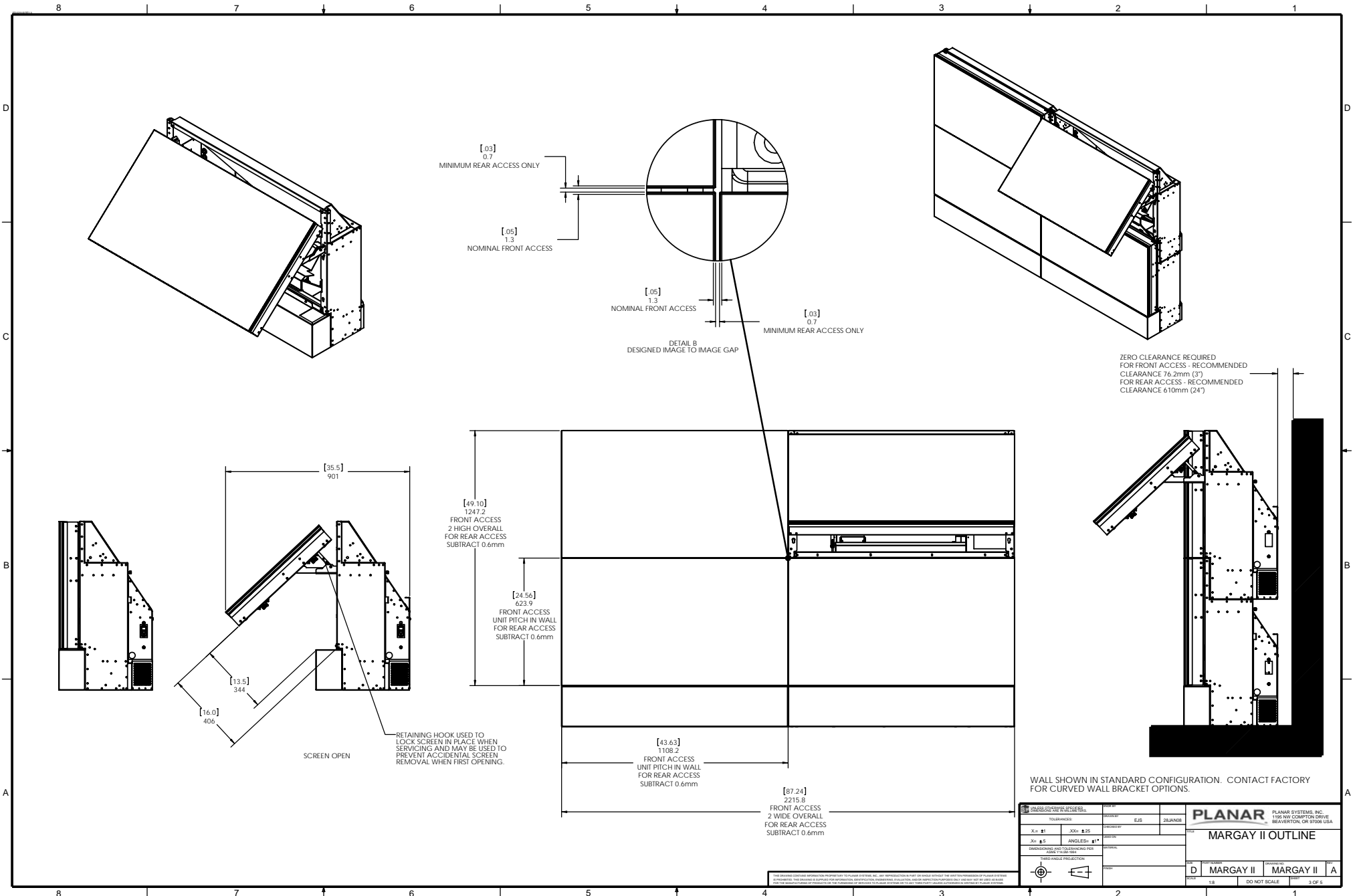

UNLESS OTHERWISE SPECIFIED: TOLERANCES: X = ±1 Y = ±5 ANGLES ±1° DIMENSIONS AND TOLERANCES PER ASME Y14.5M		DESIGNED BY EJS DRAWING NO. 214200	CHECKED BY DJL/MSJ DATE 11/10/05	PLANAR MARGAY II OUTLINE PART NO. D REV. 1.0 DO NOT SCALE	PLANAR SYSTEMS, INC. 156 NW COMPTON DRIVE BEAVERTON, OR 97008 USA DRAWN BY MARGAY II CHECKED BY MARGAY II SHEET NO. 3 OF 5
---	--	---	---	--	--

THE DESIGN AND CONSTRUCTION OF THIS PRODUCT IS THE PROPERTY OF PLANAR SYSTEMS, INC. AND IS PROTECTED BY PATENT RIGHTS. THE INFORMATION CONTAINED HEREIN IS FOR YOUR INFORMATION ONLY AND IS NOT TO BE USED FOR ANY OTHER PURPOSE. THE INFORMATION CONTAINED HEREIN IS NOT TO BE USED FOR ANY OTHER PURPOSE. THE INFORMATION CONTAINED HEREIN IS NOT TO BE USED FOR ANY OTHER PURPOSE.

OPTIONAL BASE WITH SCREEN BRACE

8mm SQUARE DRIVE
1/4-TURN HARDWARE
FOR PANEL REMOVAL
(ALL PANELS)

10mm SPANNER WRENCH TO ASSEMBLE AND ADJUST HEIGHT.
10mm SPANNER WRENCH TO LOCK HEIGHT.
CUSTOM HEIGHTS AVAILABLE UPON REQUEST.
SCREEN BRACE SOLD SEPARATELY.

HOLE FOR CABLE
ROUTES

M6X1 MOUNT POINTS FOR
CONNECTING BASES
SIDE TO SIDE (NO SIDE
PANELS)

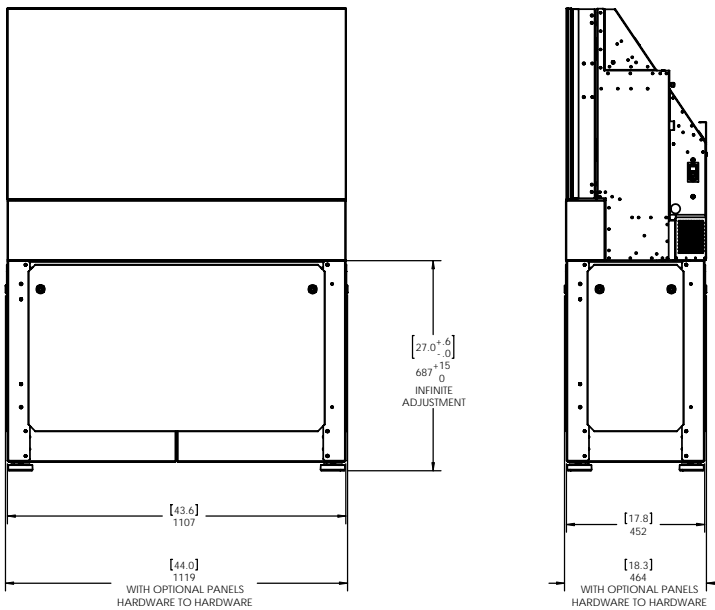

OPTIONAL FEET WITH SCREEN BRACE

PH2 DRIVER (MAGNETIC RECOMMENDED) TO ASSEMBLE.
19mm SPANNER WRENCH TO ADJUST AND LOCK HEIGHT.
SCREEN BRACE SOLD SEPARATELY.

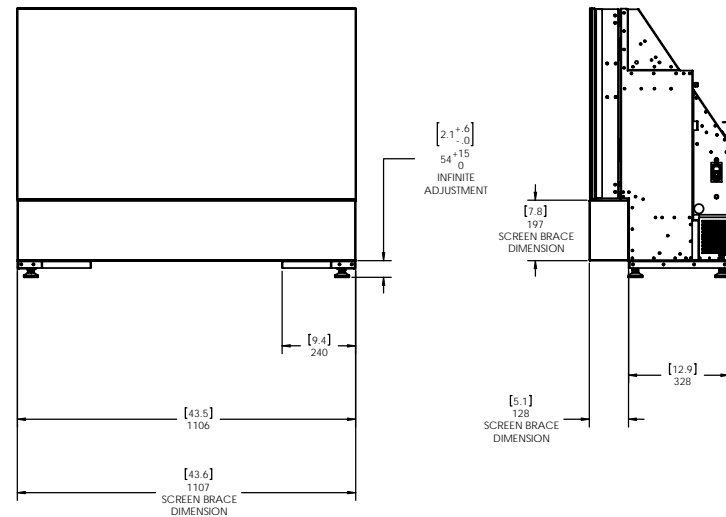
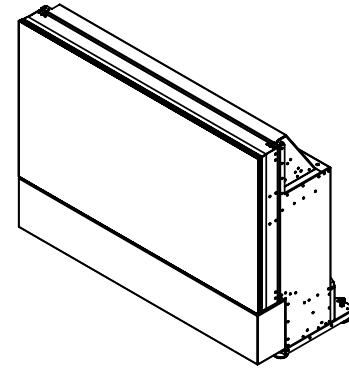

		TOLERANCES X = ±1 Y = ±5 ANGLES ±1° DIMENSIONS AND TOLERANCES PER ISO 2768		DRAWN BY EJS	DIMENSIONS 321	PLANAR SYSTEMS, INC. 156 N.W. COMPTON DRIVE BEAVERTON, OR 97008 USA
MARGAY II OUTLINE						
PART NUMBER D MARGAY II		PART NUMBER MARGAY II A		DO NOT SCALE		

THE ORIGINAL DESIGN INFORMATION FOR THIS DRAWING IS THE PROPERTY OF PLANAR SYSTEMS, INC. ANY REPRODUCTION IN PART OR IN WHOLE WITHOUT THE WRITTEN PERMISSION OF PLANAR SYSTEMS IS PROHIBITED. THIS DRAWING IS THE PROPERTY OF PLANAR SYSTEMS, INC. AND IS NOT TO BE REPRODUCED OR TRANSMITTED IN ANY FORM OR BY ANY MEANS, ELECTRONIC OR MECHANICAL, INCLUDING PHOTOCOPYING, RECORDING, OR BY ANY INFORMATION STORAGE AND RETRIEVAL SYSTEM.

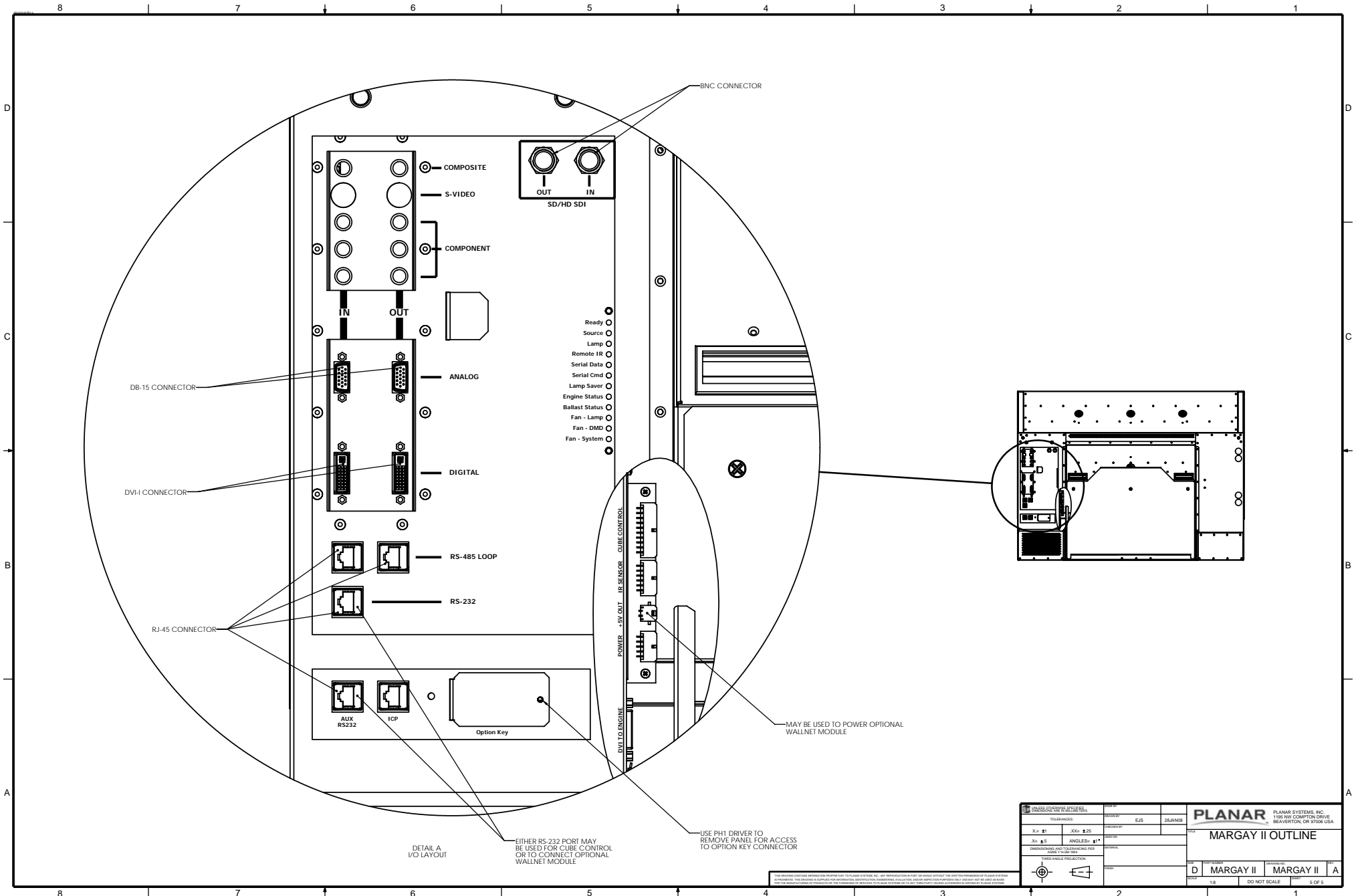

		DRAWN BY EJS CHECKED BY DILANING DATE 	PLANAR PLANAR SYSTEMS, INC. 1155 NW COMPTON DRIVE BEAVERTON, OR 97008 USA MARGAY II OUTLINE
TOLERANCES X = .1 Y = .5 DIMENSIONS AND TOLERANCING PER ASME Y14.5M	ANGLES = 1° THIRD ANGLE PROJECTION	PART NO. REV. QUANTITY UNIT 	D MARGAY II MARGAY II A 1.0 DO NOT SCALE 5 OF 5

THE DRAWING CONVEYS INFORMATION AND IS NOT A CONTRACT. PLANAR SYSTEMS, INC. DOES NOT WARRANT THE ACCURACY OF THE INFORMATION OR THE PERFORMANCE OF THE PRODUCTS DESCRIBED HEREIN. THE DRAWING IS THE PROPERTY OF PLANAR SYSTEMS, INC. AND IS NOT TO BE REPRODUCED, COPIED, OR TRANSMITTED IN ANY FORM OR BY ANY MEANS, ELECTRONIC OR MECHANICAL, INCLUDING PHOTOCOPYING, RECORDING, OR BY ANY INFORMATION STORAGE AND RETRIEVAL SYSTEM. PLANAR SYSTEMS, INC. IS NOT RESPONSIBLE FOR ANY DAMAGE TO PERSONS OR PROPERTY ARISING FROM THE USE OF THE INFORMATION OR PRODUCTS DESCRIBED HEREIN.